

MMC / SD

Memory Card Adapter

MMC / SD Memory Card Adapter.

Adding large amounts of memory to an embedded design is now extremely simple with the advent of inexpensive MMC (Multi Media Card) , SD (Secure Digital), and CF (Compact Flash) devices, because each of these devices has a capacity of many tens, if not hundreds, of megabytes of non volatile memory. The only downside to using one of the above devices is that of prototyping, as their relevant sockets are only available in surface mount packages, which can be awkward for the home user.

This is why Crownhill have released an MMC / SD adapter board that brings out the relevant pins as a convenient SIL (Single In Line) outline.

Because MMC / SD memory uses a serial (SPI) interface, there are only 6 pins to be concerned about. These are: -

- SDI** - Serial Data In to the card.
- SDO** - Serial Data out from the card.
- CLK** - Clock signal to the card.
- CS** - Card Enable. Sometimes named CE.
- GND** - Ground (0 Volts).
- VDD** - +3.3 Volts in to the card.

The adapter's pinouts are shown below: -

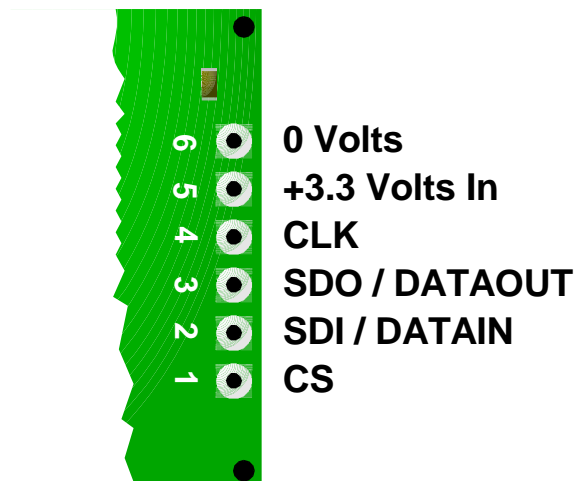

MMC / SD Memory Card Adapter.

All MMC and SD memory cards operate at approx 2.7 Volts to 3.6 Volts, and 5 Volts will certainly place it under stress, reducing it's life dramatically.

This is not an issue if the card is being interfaced to a circuit that is operating at 3.3 Volts already. And many PICmicro's will happily operate at this voltage.

However, the bulk of PICmicro™ circuits operate at 5 Volts, therefore a little ingenuity is required in order to maintain the card's integrity, and the integrity of the serial interface.

The circuit below shows one method of interfacing a 5 Volt PICmicro™ to the MMC card adapter:

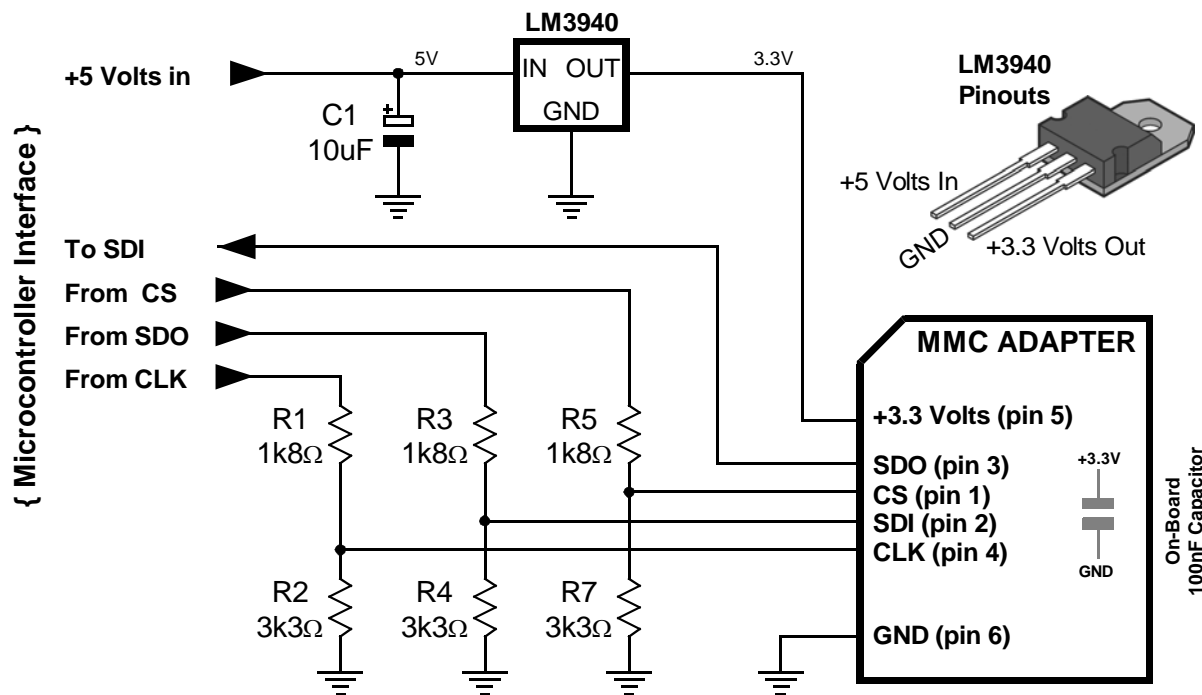

The LM3940 Low Dropout Regulator efficiently reduces the voltage from 5 Volts to 3.3 Volts. However, we still have the problem that the PICmicro™ will output 5 Volts from each of its pins when set high, placing the MMC card under stress, so simple resistor dividers are used to drop the voltage to a safe level before entering the card.

The MMC card will output high at 3.3 Volts on its SDO pin, but this is well within the logic ON level of the PICmicro™ operating at 5 Volts, so it will always interpret the highs and lows of the serial data correctly.

The LM3940 regulator comes in many packages, ranging from small surface mount types to the type used in the above circuit which is a T0220 package.